

Certikin

PLQC0800
PLQW0800

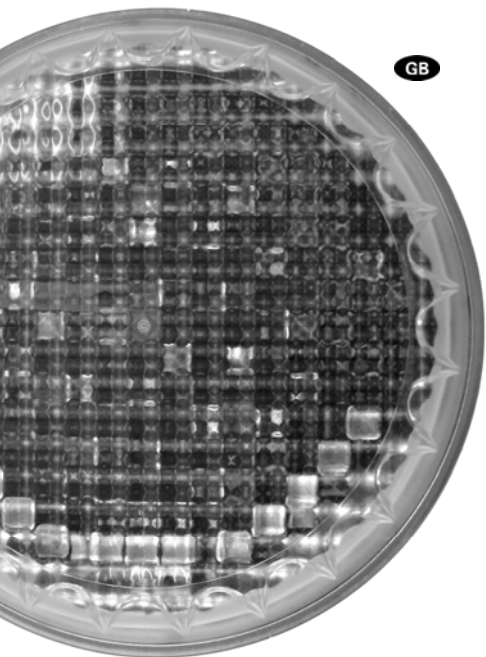

GB

PARA SUBACUATICA DE LEDS
PAR56 12V

INSTALLATION AND MAINTENANCE MANUAL

CE

ENGLISH

IMPORTANT: The instruction manual you are holding includes essential information on the safety measures to be implemented for installation and start-up. Therefore, the installer as well as the user must read the instructions before beginning installation and start-up.

Keep this manual for future reference.

To achieve optimum performance of the PAR 56 12V LED Lamp, follow the instructions provided below:

1. VERIFY THE CONTENTS OF THE PACKING:

- PAR 56 12V Led lamp
- Installation and maintenance manual

2. GENERAL CHARACTERISTICS:

This lamp has been designed to be used fully submerged. It is a Class III electric apparatus with very low safety voltage (12 V with alternating current). The lamp is class 116, in accordance with standard EN 50065.

The floodlamp complies with IPX8 degree of protection at a nominal immersion depth of 2 m.

This floodlamp complies with international safety standards for lights, especially the EN 60598-2-18 standard: LIGHTS PART 2: SPECIFIC REQUIREMENTS SECTION 18 LIGHTS FOR SWIMMING POOLS AND SIMILAR APPLICATIONS.

The manufacturer is not responsible in any circumstances for assembly, installation or start-up of any electric components which have been inserted or handled at locations other than its own premises.

3. INSTALLATION:

- In order to clearly light a pool It is recommended to install a lamp every 20 m² of water surface. In swimming pools which are especially deep, a lamp is required for every 25 m³ of water volume.
- The connection boxes should be at least 2 m. from the edge of the swimming pool or water installation.
- The 230/12V transformer supplying the lamp, should be installed 3.5 m. from the edge of the swimming pool or water installation.
- Conduits installed less than 3.5 m. from the swimming pool edge, should not be lined or covered in metal.

ATTENTION

THE HOLES AT THE BACK OF THE LAMP (FIG. 1) SHOULD BE LEFT FREE WHEN ASSEMBLING THE PROJECTOR, SO THAT WATER CAN FLOW INSIDE FOR OPTIMUM PERFORMANCE OF THE LAMP.

4. ASSEMBLY:

Follow these steps to assemble the PAR56 led lamp in an underwater projector with an incandescent lamp:

1. Ensure that the lamp is NOT receiving voltage.
2. Remove the lamp unit and the part of the projector and place it on the edge of the swimming pool (this operation is fully described in the projector manual).
3. Dismantle the parts of the projector required to remove the incandescent lamp (this operation is fully described in the projector manual).
4. Loosen the two screws which electrically connect the PAR 56 incandescent lamp.
5. Place the PAR 56 led lamp electrically connecting it with the two connection screws.
6. Assemble the projector in its initial position (this operation is fully described in the projector manual).
7. Connect the projector to the mains.

5. MAINTENANCE:

This lamp does not require any type of maintenance work. If you notice that the lamp is not working properly, please contact our customer attention service.

THIS PRODUCT DOES NOT CONTAIN ANY ELEMENTS THAT CAN BE HANDLED, DISMANTLED OR REPLACED BY THE USER. IT IS FORBIDDEN TO ACCESS INSIDE THE PRODUCT, OTHERWISE THE GUARANTEE OF THE PRODUCT WILL BECOME INVALID.

6. CONTROL SYSTEMS OF THE LED LAMP:

The lamp PLQW0800 does not need any control since it|she emits only white light.

The lamp PLQC0800 if it needs control for the change of color and of sequences.

The lamp PLQC0800 can be controlled in two different ways: either by a normally closed pushbutton or by means of the CONTROL BOX and/or remote control

In both cases, you should make sure that the voltage received by the lamp is never more than 12V.

The lamp should only be operated underwater and anchored to the vertical walls of the pool. The lamp is supplied with heat protection, which in the event of excess temperature reduces the lighting level to avoid overheating.

6.1. PUSHBUTTON CONTROL

The system has **12 operation modes: 6 set colours and 6 sequences of different colours** (see section 6.3) The colour or sequence is changed by a quick press of the pushbutton. The lamp/s is/are placed in white if the pushbutton is pressed for longer.

6.1.1. Electrical connection diagram

The system is composed of the projector/s, the transformer and the normally closed (NC) pushbutton.

The transformer must be able to supply 45VA for each led lamp connected. For example, if you want to control 5 lamps, you must connect them in parallel to a transformer of at least 225VA. The pushbutton must be able to withhold the power consumed by the number of lamps installed.



6.2. BOX CONTROL AND/OR REMOTE CONTROL

The system has **12 operation modes: 6 set colours and 6 sequences of different colours** (see section 6.3).

The CONTROL BOX controls switching the lamps on and off, changes of colour and sequences and switching off timing.

If you have a remote control, apart from the CONTROL BOX operations.

6.2.1. Electrical connection diagram

For correct installation, you will need the CONTROL BOX, the transformer and finally the led lamp. As an option, this system can be controlled by Remote Control. For more information on the installation of the Receiver-Modulator, see point 6.2.3. and section 6.2.4. includes information on the Remote Control.

The CONTROL BOX is connected to the 230 Vac mains by means of two terminals indicated MAINS, and to the primary input of the transformer (230 Vac) by means of the terminals indicated TRF (See attached diagram).

The transformer must have the capacity to supply 45 VA to each led lamp connected. For example, if you want to control 5 lamps, they should be connected in parallel to a transformer of at least 225VA.

Each CONTROL BOX can control up to a maximum of 15 LED spotlights.



Once the unit is connected, proceed as follows to start-up the projector for the first time:

- Switch on the unit by activating the 230 Vac. at the input of the CONTROL BOX, which will automatically syntonize with the transformer. The green led of the CONTROL BOX will flash every 2 seconds and the lamp will remain off.

6.3 OPERATION MODES

The unit enables different light scenarios to be created inside the swimming pool with two operation possibilities:

Set colour: Selection of one set colour out of six possibilities.

COLOUR N°	% RED	% BLUE	% GREEN	COLOUR
1	100	100	100	White
2	100	0	0	Red
3	0	100	0	Blue
4	0	0	100	Green
5	100	100	0	Purple
6	0	100	100	Cyan

Automatic sequence of colours: Selection of nine colour sequence programmes. Each programme is defined by the lighting time of each colour and the transition time from one colour to another according to the following table:

SEQUENCE	ORDER OF COLOURS						COLOUR TIMING (SEC.)	BLENDING TIMING (SEC.)
1	Red	Blue	Green	Purple	Cyan	Yellow	2	2
2	Red	Green	Cyan	Blue	Purple	Yellow	4	4
3	Purple	Cyan	Yellow	-	-	-	4	4
4	Red	Blue	Green	-	-	-	8	8
5	Purple	Cyan	Yellow	-	-	-	18	18
6	Yellow	Purple	Cyan	-	-	-	0,5	0,5

The colour or sequence is changed by pressing the pushbutton. The colour and sequence cycle is rotary. For example, if you are in colour 5, by pressing once, you will reach colour 6. If you press once again, you will go to sequence 1. If you are in sequence 6, press once and you will get to colour 1, which is White.

7. SAFETY WARNINGS:

- **Avoid making contact with the electric voltage.**
- **Comply with the current standards regarding accident prevention.**
- **In this regard, the IEC 364-7-702 standards must be observed: WIRING IN BUILDINGS SPECIAL WIRING SWIMMING POOLS**
- **All maintenance operations should be performed with the lamp disconnected from the Mains.**
- **Do not handle with wet feet.**
- **The manufacturer is not responsible in any circumstances for assembly, installation or start-up of any electric components which have been inserted or handled at locations other than its own premises.**

8. ENVIRONMENTAL INFORMATION

Processing of electrical and electronic equipment after their period of use (Only applicable in the E.U.)



Our goods are designed and manufactured using top quality materials and components, which are environment-friendly and which can be reused and recycled. This symbol, marked on the equipment or packaging, means that this equipment can not be processed as normal domestic waste. You should hand it in to the technician who installs the new equipment or at special collection points for electric and electronic equipment. Recycling this equipment does not cost you anything and by separating it from other waste, you are helping to prevent negative consequences for the environment and for people's health by avoiding incorrect handling. Help us to preserve the Environment. Thank you.

For detailed information on how to correctly dismantle this equipment for recycling, please contact us through quality@sacopa.com

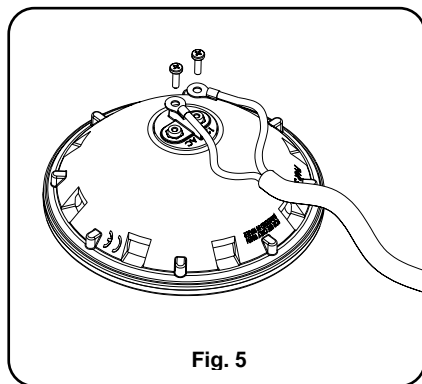
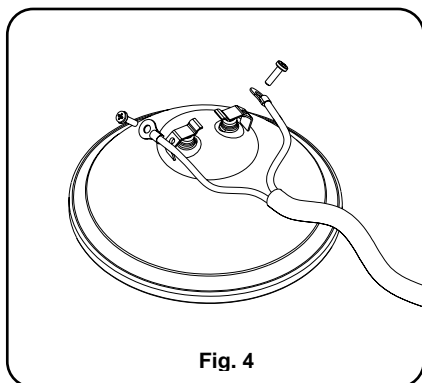
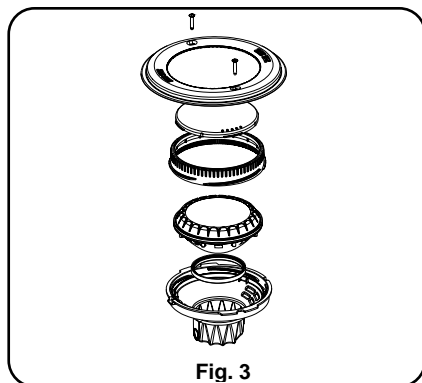
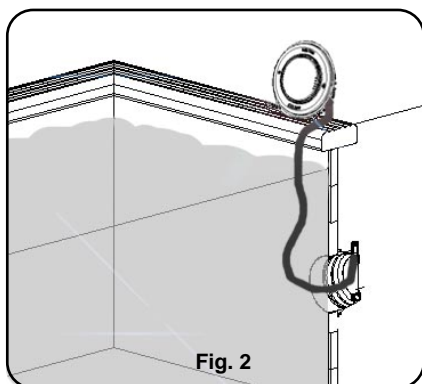
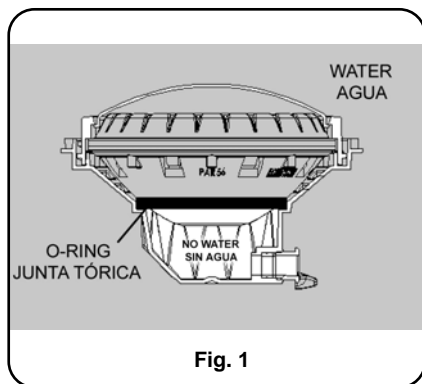

UK PRODUCTS:

PLQC0800
PLQW0800

DECLARATION CE OF CONFORMITY

The products listed above are in compliance with:

Electromagnetic Compatibility Directive 89/336/EEC.

Low Voltage Directive 73/23/EEC.

European Standard EN 60598-1, EN 60598-2-18, and all its modifications.

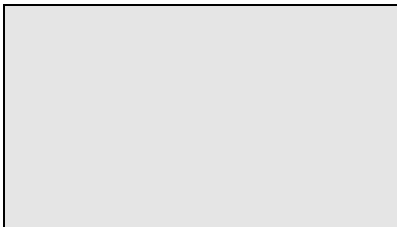

Signature / Qualification:

SACOPA, S.A.U.
Pol Ind. Poliger Sud – Sector I, s/n
17854 SANT JAUME DE LLIERCA
SPAIN

St. Jaume de Llierca, 1
November of 2007

GERENT

TECHNICAL CHARACTERISTICS

DESCRIPTION	
Rated voltage / Tensión nominal / Tension nominale / Tensione nominale / Tensao nominal	12 V
Current suply / Tipo de corriente / Type de courant / Tipo di corrente / Tipo de corrente	AC
Power / Potencia / Pouvoir / Potere / Poder	45W
Degree of protection / Grador de protección / Degré de protection / Grado di protezione / Grau de proteção	CLASE III IPX8
<p>TO BE USED ONLY WITH A SECURIY TRANSFORMER EN 60472 PARA USO EXCLUSIVO CON TRANSFORMADOR DE SEGURIDAD EN 60472 À UTILISER UNIQUEMENT AVEC UN TRANSFORMATEUR DE SECURITÉ EN 60472 DA USARE ESCLUSIVAMENTE CON TRANSFORMADOR DI SEGURIDADE EN 60472 PARA USO EXCLUSIVO COM TRANSFORMADOR DE SEGURIDAD EN 60472</p>	

35604E201 IP144-00

Made in EC
Sacopa, S.A.U.
Pol. Ind. Poliger Sud – Sector I, s/n
17854 Sant Jaume de Llierca (Spain)

- We reserve to change all or part of the articles or contents of this document, without prior notice.
- Nos reservamos el derecho de cambiar total o parcialmente las características de nuestros artículos o contenido de este documento sin previo aviso.
- Nous nous reservons le droit de modifier totalment oru en partie les caracteristiques de nos articles ou le contenu de ce document san pré avis.
- Ci riservamo il dritto di cambiare totalmente o parzialmente le caratteristiche tecniche dei nostri prodotti ed il contenuto di questo documento senza nessun preavviso
- Reservamo-nos no direito de alterar, total ou parcialmente as características dos nossos artigos ou o conteúdo deste documento sem aviso prévio