

COMMERCIAL PUMPS - BIG DENVER



Features

Certikin's Big Denver pump range is ideal for smaller commercial applications.

- Pump body manufactured in fibre-glass and mineral reinforced polypropylene and transparent polycarbonate cover
- 316 stainless steel shaft
- Plastic impellor
- Pre-filter capacity 8 litres
- IP55 protection rated
- Suction connection Ø90 and return connection Ø70 (supplied with couplings and metric unions)
- Self priming at 2m

Big Denver Pumps - 50Hz

Code	Description
BDP350T	3HP - 3 phase
BDP400T	4HP - 3 phase
BDP550T	5.5HP - 3 phase

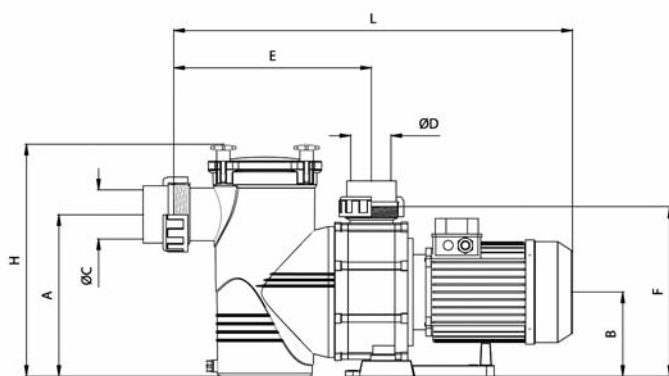
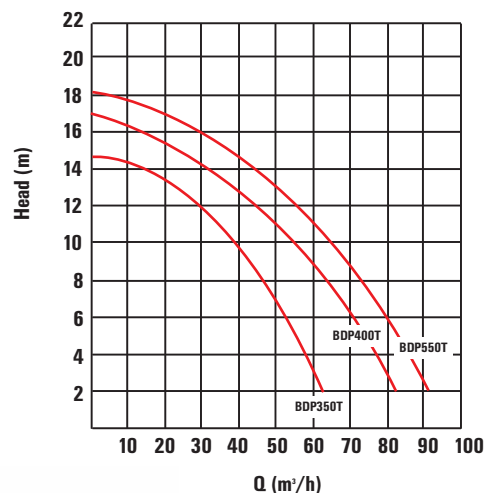

Big Denver Pumps													
Code	kW	HP	A	B	C	D	E	F	G	H	L	Gross Weight	Volume (m ³)
BDP350T	2.2	3	300	160	Ø90	Ø75	368	320	264	431	713	22	0.12
BDP400T	2.9	4	300	160	Ø90	Ø75	368	320	264	431	743	25	0.12
BDP550T	4	5.5	300	160	Ø90	Ø75	368	320	264	431	743	27	0.12